



**LIFT ANYWHERE YOU NEED!**



• Glazing

• Steel erection

• Maintenance

• Timber roofs

• Industrial plants

• Artwork moving

 **CONEXPO 2008**  
meet us at booth  
RL-41030



Imai srl Via Campardone, 7 Z.I. 31014 Colle Umberto (TV) Italy tel. +39 0438.430171 fax +39 0438.430115 www.jekko.it e-mail: info@jekko.it



## ALLMI accredited Lorry Loader Operator Training Providers

### Nationwide

**T H WHITE**

Contact: David Ottaway 01380 722381

Email: cranes@thwhite.co.uk

www.thwhite.co.uk

Nursted Road Devizes

Wilts SN10 3EA



### Ireland



Church Road, Tullamore, Co. Offaly, Ireland

Tel: 086 2500 825 Mobile: 086 1042 787

### Nationwide



Wharfedale Road, Euro Way Ind. Est. Bradford. BD4 6SL

Tel: 0870 017 0606

Web: www.atlascranes.co.uk

### Nationwide



Hiab Ltd

Cargotec Industrial Park, Ellesmere, Shropshire, SY12 9JW

Tel: 01691 626427 Fax: 01691 626472

e-mail: training.uk@hiab.com • Web: www.hiab.co.uk

Are your Lorry Loader Operators properly trained? Call a certified ALLMI training provider and Insist on the ALLMI card.

## The training accreditation service of Lorry Loader Manufacturers and Importers

ALLMI Second Floor Suite, 9 Avon Reach, Monkton Hill, Chippenham, Wiltshire. SN15 1EE

TEL: 01249 659150 email: enquiries@allmi.com web: www.allmi.com

# Non Destructive testing

Following feedback from the industry regarding the lack of information available on Non-Destructive Testing (NDT), the ALLMI Technical Committee carried out extensive research throughout 2007 and will shortly publish a Guidance Note on the subject which will be available to download from ALLMI's website. The following is a brief overview on the subject.

Non-destructive testing covers a variety of non-invasive techniques used to determine the integrity of a material, component or structure without harming, stressing or impairing its future usefulness. The British Standard for The Safe Use of Lorry Loaders (BS 7121 Part 4), recommends that a non-destructive test of the crane's structure is made in conjunction with a thorough examination, eight years after the crane first entered service.

The first stage is to thoroughly clean the crane, removing grease and grime prior to a thorough visual inspection. In the case of a more in-depth analysis the crane may require dismantling and/or removal of some paint. The extent of this preparation depends greatly on the NDT method being used (however, blistered, flaking or cracked paint must always be removed - and then made good to prevent corrosion). Before carrying out the inspection, it's essential that a risk assessment is carried out, with particular consideration on how to safely reach all parts of the crane, taking fall prevention measures as appropriate. Suitable tools and protective equipment must also be used.

There are a variety of NDT tests, each based on a particular scientific principle. The following are those most commonly used:



## Visual Inspection

Look for paint cracks. Steel exposed by a paint crack will come into contact with rainwater or salt air and rust. Telltale reddish-brown signs are easy markers of places to start looking for cracks, but be aware that visual signs of failure may not always be apparent, e.g. rust / cracks painted over.

## Electromagnetic Testing

Detects cracks on and below the surface by inducing electric currents or magnetic fields into the test object, such as a weld, and observing the electromagnetic response often with iron powder. This method is very accurate and has the ability to test complex shapes, but it is limited by the depth of inspection.

## Dye Penetrant Testing

Employs a penetrating dye, which is applied over the surface of the component and enters clean, dry and open defects. The inspection is carried out by first cleaning the surface to remove foreign material in the crack. The penetrant is then applied to the surface and allowed to soak into the cracks. Excess penetrant is then removed and a developer applied which draws penetrant from the cracks out onto the surface.

This method only detects surface defects in non-porous materials, but can be used on a wide variety, including metals, plastics and ceramics.

## Magnetic Particle

Very fine dyed magnetic particles are suspended in a liquid and painted onto the test surface. Cracks on and below the surface are indicated by a gathering of the dyed particles, due to a distortion of the magnetic field, which is caused by the crack. It is necessary to grind the surface at

suspect crack locations to ensure against false positives/negatives. This grinding can help prevent fatigue cracks by removing weld toes, for example, without compromising the structure. Note that this method is not suitable for non-magnetic materials and is not suited to complex objects. However it is possible to test through uncracked paint with this method.

## Ultrasonic

Uses high frequency pulse waves to detect flaws in materials and can also measure an object's thickness (e.g. the degree of corrosion inside a pipe). The pulse waves are transmitted through the material and any defects cause reflections of the sound. By measuring the time difference between the transmission and the reflected sound an estimate of the defect's depth can be made. Ultrasonic testing can detect flaws at a superior depth in a wide variety of materials.



## Radiographic Testing

Uses short wavelength electromagnetic radiation (e.g. X-ray) to detect hidden flaws in various materials by measuring the intensity of radiation through the test object. Surface defects may require grinding to smooth the surface before analysis, in order to ensure that a clear image of a crack can be seen on the radiograph, which may otherwise be obstructed. Penetrants can be used to make surface cracks more visible.

The following are some example areas to be checked when performing the visual inspection:

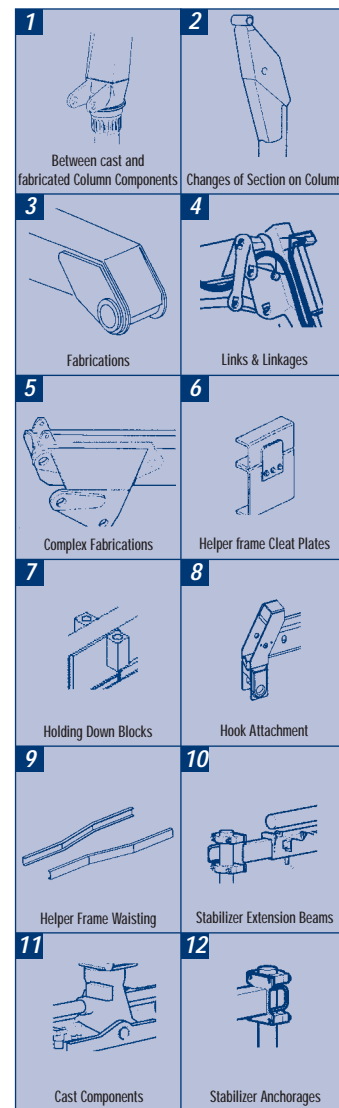

All of the above areas should initially, be visually inspected, although for points 1 and 2 it would be prudent to also use Ultrasonic or Magnetic Particle testing due to the critical nature of the welds. Any suspected cracks found by the visual inspection should be further checked with one of the other techniques.

In addition to the testing methods and procedure, it must be ensured that any certificates and/or reports of NDT, are appended to the Report of Thorough Examination. Lorry loader owners should also be aware that the competent person performing the test should be qualified in the techniques of NDT (BS EN 473 'Non Destructive Testing Qualification and Certification NDT Personnel - General Principles', details the required qualifications and certification of NDT personnel).

